



University of
Salford
MANCHESTER

A systematic approach for evaluating the requirement for service of party structure notices

Chynoweth, P

<http://dx.doi.org/10.1108/02637470010348753>

Title	A systematic approach for evaluating the requirement for service of party structure notices
Authors	Chynoweth, P
Type	Article
URL	This version is available at: http://usir.salford.ac.uk/12460/
Published Date	2000

USIR is a digital collection of the research output of the University of Salford. Where copyright permits, full text material held in the repository is made freely available online and can be read, downloaded and copied for non-commercial private study or research purposes. Please check the manuscript for any further copyright restrictions.

For more information, including our policy and submission procedure, please contact the Repository Team at: usir@salford.ac.uk.

A Systematic Approach for Evaluating the Requirement for Service of Party Structure Notices

Author:

Paul Chynoweth BSc (Bldg Surveying) LLB Solicitor

Lecturer in Property Law & Surveying at the University of Salford.

Brief Autobiographical Note:

Background in the legal profession, specialising in Property Law. Involved in the education & training of chartered surveyors since obtaining surveying degree in 1993. Member, editorial board, *Structural Survey*. Also undertakes professional consultancy work in boundary and party wall matters and sits on the RICS Boundaries & Party Walls Practice Panel.

Contact Details:

School of Construction & Property Management
University of Salford
Salford
M5 4WT
United Kingdom

Tel: +44 (0)161 295 3092

Fax: +44 (0)114 266 8217

Mobile: 0958 951 184

E-mail: chynoweth@mail.com

Web: www.partywalls.com

A Systematic Approach for Evaluating the Requirement for Service of Party Structure Notices

Keywords: *Party Wall, Party Structure, Party Structure Notice, Boundary, Trespass*

Abstract: *The Party Wall etc Act 1996 makes provision for the service of party structure notices on adjoining property owners where certain types of work are undertaken to party walls and other structures between neighbouring properties. The paper emphasises the difficulty of determining whether a notice should be served in a particular situation and the importance for property managers of making a correct decision. A systematic approach is proposed whereby each of the component parts of the task is addressed separately before a final decision is made. The paper examines these component parts and applies the relevant legal rules to each in the context of circumstances frequently encountered in practice.*

Introduction

The Party Wall etc Act 1996 (PWA) has been in force since 1st July 1997. It regulates building operations in a variety of circumstances where these are undertaken in close proximity to the boundary line between two properties.

The construction of new walls at a boundary position (s.1) and the excavation of land adjacent to neighbouring buildings (s.6) are both included within the ambit of the legislation. Property managers are however most often affected by the Act's provisions in the context of the repair, maintenance or refurbishment of buildings where some of the work affects an existing boundary structure (s.2).

This type of work may potentially require the service of a party structure notice on adjoining owners prior to commencement (s.3) but the circumstances in which this is appropriate are often difficult to determine with certainty on site. This difficulty is aggravated by the precise requirements of the relevant statutory provisions and the generalised nature of some of the existing published guidance in this area.

An incorrect analysis of a particular situation will have serious consequences. A failure to serve a notice, where required, will result in the commission of a trespass against an adjoining owner, whilst an unnecessary service will result in increased costs to the property owner and avoidable delays to the progress of the work. The service of an incorrect notice will have similar results.

To minimise the risk and uncertainty inherent in the process, this paper proposes a systematic approach to be used by property managers for evaluating the requirement for service of party structure notices. It describes the stages of this approach and outlines the legal principles applicable at each stage.

Party Structure Notices

The function of a party structure notice is to alert adjoining owners, who may be affected by work to a neighbouring property, to the nature of the proposed work. Whilst they have no right to prevent the work proceeding, the legislation provides them with statutory consultation rights regarding the detailed specification and manner of carrying out the work.

A notice must be served at least 2 months prior to commencement but if the recipient fails to consent to the proposed work within 14 days the legislation deems that the parties are in dispute. Each then appoints a surveyor to act on his behalf in negotiating a set of fair and workable proposals which, in due course, are embodied

within a statutory award. Subject to a 14 day right of appeal to the county court (s.10(17)) the award then regulates the rights and duties of each of the parties in the conduct of the work.

Approach to Evaluation

The numerous circumstances in which party structure notices are required are set out as a series of rights in section 2(2) of the Act and, contrary to the impression given by the statute's title, it cannot simply be assumed that determining the existence of a party wall is the sole criterion for assessing the need for service of a notice. Section 2(2) authorises a variety of different categories of building operation but relates each of these to a specific type of boundary structure of which a party wall is only one. It is only where the proposals fall within a specified category and also apply to a related structure type that a notice is required.

Any reliable approach to evaluating the need for service must therefore involve a thorough assessment of the precise legal status of the boundary structure affected by the proposed work. Having established the status of the structure, the exact nature of the proposed work should also be fully considered. Finally, an evaluation of the significance of the work to the structure can then be made in the context of the detailed provisions of section 2(2), to determine whether a notice will be required.

The various issues raised by this three-stage approach will now be considered.

Boundary Structures

A close reading of section 2(2) reveals that rights to undertake building work are granted in respect of up to nine other structure types, in addition to the ubiquitous party wall. These will be considered, but let us first acquaint ourselves with the nature of the party wall itself.

Party Wall

The common law attributes four different meanings to the term (*Watson v Gray 1880*) and, in ordinary language, a party wall can certainly describe any wall separating adjacent buildings (Rudall 1922, p.1). In the present context the term is restricted to only two types of structure which are defined as such within section 20 of the PWA. Following the paragraph structure of that section, these are now commonly referred to as 'Type A' and 'Type B' party walls.

A 'Type A' party wall is a wall that forms part of a building and whose thickness straddles the boundary line between two properties in different ownership (Figure 1). A free-standing wall (for example, a garden wall) therefore falls outside this definition, as does a wall where only its projecting footings cross the boundary line. The definition is wide enough to include the external wall of a building where it straddles a boundary line and is not therefore confined solely to internal walls separating two buildings.

[Take in Figure 1]

Where a wall forming part of a building is situated entirely on one side of a boundary line it will fall outside the above definition. However, any part of such a wall that divides the building from an adjoining building is a 'Type B' party wall (Figure 2). Where the entire height and width of the wall performs this function the entire wall is therefore a party wall. Where only part of the wall is affected in this way it is only this part that can be classed as 'party' for the purposes of the Act. The typology specified in the Act only has relevance in determining the status of the wall. Once the status of party wall is established, the Act makes no further distinction between the two types which are the subject of identical rights.

[Take in Figure 2]

Party Fence Wall

A distinction is however made between the rights granted by section 2(2) in respect of party walls and those granted in respect of walls, not forming a part of a building, whose thickness nevertheless straddles the boundary line between two properties. This type of structure (typically a garden wall between properties) is described by the Act as a 'party fence wall' (Figure 3) and entitles an owner to lesser rights than those bestowed upon the owner of its 'party wall' cousin. The Act bestows no rights at all in respect of fences, or indeed hedges or any other type of freestanding boundary structure, as the confusingly named 'party fence wall' is defined to include only walls.

[Take in Figure 3]

Party Structure

Much confusion is also caused by rights granted by section 2(2) in respect of 'party structures'. The term is commonly interpreted as referring to floor, ceiling and staircase structures separating self-contained units (maisonettes, flats or office suites) within a single building and on this basis it can be seen as an extension of the 'Type B' party wall principle to non-vertical structures.

These structures are indeed defined as falling within the term but so, crucially, are party walls (as defined above). The term is therefore used as shorthand by the draftsman to include situations where rights are to be granted in respect of the horizontal structures referred to above *in addition to* rights granted in respect of party walls. A failure to appreciate this use of Parliamentary language has sometimes resulted in a failure to recognise that important rights are available in respect of party walls in addition to those affecting horizontal structures.

External Wall

There are references throughout the Act to 'external wall' which indicate that certain rights are intended to be granted in respect of walls entirely on one side of the boundary line and falling outside the definitions of party wall and party fence wall. Section 2(2)(g), for example confers a right for a property owner to cut away projections from a neighbour's external wall which intrude onto his land.

The term is not defined however and opinions vary as to the precise meaning. Anstey (1996, p.26) suggests that the term is synonymous with the expression 'the external wall of a building' which also appears in the legislation, whilst Bickford-Smith (1997, p.11) argues that, unless so qualified, the term is broad enough to also include a free-standing wall.

Reference to earlier party wall legislation supports Anstey's interpretation. The LBA 1930 (s.5) defined the term as 'an outer wall, or other vertical enclosure of any building, not being a party wall'. As this definition was also incorporated into the LBA 1939 (s.1), upon which the PWA is largely based, it is likely that this meaning was also anticipated by the draftsmen of the present Act.

Anstey's position receives further support, in the current context, from section 2(1) of the PWA which makes reference to the 'external wall of a building' in defining the scope of the whole of section 2. It is therefore submitted that, whatever the correct interpretation of 'external wall' in other parts of the Act, its meaning in the context of the current discussion must be confined to external walls of neighbouring buildings (Figure 4).

[Take in Figure 4]

Boundary Wall

The term 'boundary wall' also appears throughout the Act and, once again, no definition is provided. Anstey (1996, p. 25) considers that the expression refers to a free-standing wall standing wholly on the land of one owner whilst Bickford-Smith (1997, p.11) argues for a broader interpretation. He suggests that the term refers to any wall which marks a boundary, whether astride it or next to it and whether forming part of a building or free-standing.

The term is often qualified within the statute so as to include only a particular type of 'boundary wall'. A reading of the relevant provisions (for example, ss. 1(1) & 2(1)) appears to confirm Bickford-Smith's view of the unqualified term as applying to any wall which delineates a boundary, however and wherever it may be constructed.

In the context of determining the requirement for service of a party structure notice, we must have regard to the qualification imposed by section 2(1). This restricts the meaning to two types of structure which we have already considered, namely a party fence wall and an external wall of a building (Figure 5). Despite the general meaning of the unqualified term, we should therefore, in the current context, interpret rights granted in respect of boundary walls as only referring to these two types of structure. The term is therefore another example of the draftsman's shorthand and, as with references to party structures, a failure to appreciate the language can cause the nature of the right being granted to be misinterpreted.

[Take in Figure 5]

Other Boundary Structures

In addition to the references to the structures so far considered, section 2(2) also authorises specific categories of work to a variety of other boundary features which

are described in everyday non-technical language. By way of illustration, a reference in section 2(2)(j) to 'the wall of an adjoining owner's building' appears to be self-explanatory and presumably requires no more precise definition. This is also the case with the remaining features but their inclusion within the section is a further reminder that party structure notices are not only required for work to party walls.

On-site Considerations

Difficulties on Site

It will be clear from the above that identification of structure types anticipated by the legislation will not always be straightforward. The difficulties inherent in the process are unfortunately compounded when applying the detailed requirements of the rules to the realities of a situation on site.

Boundary features are often far from homogeneous in their construction, making it difficult to define the limits and extent of a structure with certainty. An example of this is illustrated in Photograph 1. It is not unusual for different parts of an apparently single structure to have been erected at different times using a variety of materials and construction techniques. It may also be found that a feature varies in thickness or incorporates recent increases in thickness along its length. In many situations it is therefore difficult, from a legal standpoint, to determine whether a boundary feature comprises a single structure or whether two or more structures are incorporated within the single entity.

[Take in Photograph 1]

The precise location of the legal boundary line, the most significant factor in classifying many of the structures referred to in the legislation, is also notoriously difficult to identify on site. This combination of a structure of indeterminate thickness

and a boundary line of uncertain location can make the already difficult task of interpreting the legislation's definitions somewhat daunting. A logical approach to the evaluation of on-site factors and to the application of the relevant legal principles to them should therefore be regarded as an essential feature of the process.

Homogeneity of Boundary Features

It must always be a question of fact as to whether a feature forms a single structure or a combination of structures. This must involve the application of ordinary language and common sense principles.

A frequently encountered example (illustrated in Photograph 2) concerns the situation where two separate buildings, each having their own skin of brickwork are constructed on either side of the boundary line but immediately adjoining each other. Where, as a matter of fact, the two skins of brickwork can be properly described as forming a single wall standing astride the boundary line, a 'Type A' party wall exists. Where, on the facts, the two skins can more properly be described as two separate walls then each skin will constitute an 'external wall' within the meaning of the Act.

[Take in Photograph 2]

Different approaches have been suggested for determining the degree of connection that will be required between the skins before they become a single wall. Bedford (1999) suggests that the required degree of proximity will exist if it is no longer possible to see daylight between them. Most other commentators emphasise the requirement for the two skins to perform as a single structural entity before classifying them as a single wall and it is suggested that this is likely to be the preferred approach in most situations.

Rance (1999) notes that this requirement will often be satisfied by the presence of masonry bonding or metal ties between the two skins but considers that the presence of mortar between the two skins will not, of itself, be sufficient. Keogh (1999) and Bowden (1999a) both adopt a more functional approach and suggest that the most helpful test is whether one skin is capable of independent existence without the other. The failure of one skin to satisfy the requirements of the Building Regulations (Bowden 1999a) or the impairment of one skin by the demolition of the other (Keogh) would therefore suggest that the two skins together constitute a single wall.

Although none of these approaches should be seen as a panacea for all situations, they can perhaps all be regarded as useful aids to decision-making if applied in appropriate circumstances.

Location of Legal Boundary Line

The above discussion assumes that the position of the boundary line is known in advance, whereas in reality this will rarely be the case. An attempt must therefore also be made to assess the location of this invisible line (referred to within the legislation as the 'line of junction') before the status of a structure can be assessed.

In undertaking this assessment it is helpful to appreciate that, unless there has been a subsequent change in the situation, the line will be in the position that the original owners of the two plots intended it to be in at the time the plots were first subdivided. The task is therefore concerned solely with establishing this intention and all factors that might be considered in the course of the exercise simply provide evidence as to the nature of this intention.

In complex situations, or where the works are likely to be contentious, title documents should be referred to and legal assistance obtained where this is considered

appropriate. The original conveyance at the time of the sub-division might be expected to contain the required information and where this is clear and unambiguous it will form conclusive evidence of the boundary location (Powell-Smith 1975, p.34).

Unfortunately, in the United Kingdom, boundaries are rarely defined with mathematical precision. Boundary descriptions in deeds are often made by reference to existing boundary features which may have changed since the date of the deed. In any event boundary features have a physical thickness and the position of the invisible boundary line can theoretically lie at any point within this thickness, or indeed on either face of the feature.

Where a boundary is defined by reference to a deed plan, discrepancies will often exist between the plan and the site, even where based on an Ordnance Survey map. It must also be appreciated that there are accuracy limitations that prevent the precise identification of a boundary line from even the most carefully prepared plan. A line drawn on a 1:1250 scale plan, for example, will represent approximately 0.3 metres on the ground. Because of these limitations, plans can usually only be taken as establishing the general indication of boundaries rather than their exact location and this practice is given formal expression in the Land Registry's General Boundaries Rule (LRR 1925, Rule 278).

For all these reasons the title documents will rarely provide conclusive evidence of the location of the boundary line. Other available evidence, especially that from the site itself, will have to be relied on in establishing the intention of the original owners in this context.

As a general rule, evidence that one party erected a boundary feature will suggest that the boundary line lies somewhere on his neighbour's side of the feature. Evidence as to the construction of a boundary feature can, in turn, suggest which party is likely to have erected it. The presence of buttresses on one side of a wall, for example, can be taken as an indication that the owner of that land was responsible for the erection of the wall (Wignall 1998, p.100). Where the external wall of a building is erected at a boundary location it will be presumed that the boundary line is marked by the face of the wall (*Truckell v Stock 1957*). However, in circumstances where a boundary feature can be shown to be used by both parties, for example as a wall between two terraced houses, the boundary is presumed to run down the centre of the structure (*Cubbitt v Porter 1828*, LPA 1925, Schedule 1 Part V). On-site evidence of joint user will therefore confirm that a structure will be classified as a party wall, party fence wall or party structure under the Act.

Design Proposals

Nature of Work

Having established the legal status of the boundary structure affected by the proposed work, the precise nature of the work itself can then be addressed to determine whether the particular situation requires service of a party structure notice. This may often involve pressing appropriate members of the design team for greater detail than they may be used to providing at an early stage of the project.

Evaluation of Work

Once this information is available the design can be evaluated to determine whether it incorporates any of the particular categories of work to the particular structure types envisaged by section 2(2) of the Act. The section includes 13 separate paragraphs, each describing a variety of work categories and structure types.

To take a straightforward example, paragraph (f) authorises a building owner 'to cut into a party structure for any purpose'. If the proposed work can therefore properly be described as 'cutting in' and the structure has also been correctly identified as a 'party structure' then the work is clearly authorised by the legislation and, as such, a party structure notice must be served (s.3).

If either of these two requirements does not apply then, unless the proposal falls within one of the other paragraphs within the section, the work is not authorised. Subject to the considerations discussed below, the question of serving a notice will therefore probably not arise.

The situation is complicated by the presence of common law property rights which exist in parallel with the rights created by the section and which also influence the appropriate course of action in any particular instance. At common law, property owners generally have an absolute right to undertake construction operations on their side of the legal boundary line (*Jones v Pritchard 1908*) but no right to do so on their neighbour's side without permission as this would amount to a trespass (*Apostal v Simons 1936* and *Moss v Smith 1977*).

The rights within section 2(2) are superimposed onto these common law rights and will be shown to represent both extensions and restrictions to them in particular circumstances. The interaction of the statutory and common law regimes will be seen to produce three different scenarios which each require their own particular response from a property owner before work is commenced. Each of these will now be considered.

Scenario 1: Requirement for Party Structure Notice

The first scenario applies where one of the paragraphs in section 2(2) fully describes the proposals under consideration. An example of this has already been mentioned in the context of cutting into a party structure under section 2(2)(f). Before any of the rights contained within section 2(2) can be exercised, section 3(1) provides that a party structure notice must first be served. In this first scenario it would therefore appear that a notice will always be required by virtue of these two provisions.

The only complication concerns the status of the property owner's unconditional common law right to undertake work *to his own side* of the party structure. It has been suggested (Bowden 1999b) that this right survives the enactment of the PWA and that, providing the work does not encroach onto the neighbour's side of the boundary line, there is therefore no need to rely on the statutory rights under section 2(2) and consequently no requirement to serve a notice under section 3(1). However Anstey (1996, p.28) considers that the statutory rights replace those at common law. He argues that the owner's previously unfettered rights in respect of his own side of the structure no longer exist and that his rights are now conditional upon the prior service of a party structure notice.

Anstey's interpretation is supported by *obiter dicta* of Jessel MR in *Standard Bank of British South America v Stokes* (pp. 73 - 74). This view is also more sympathetic to the spirit of the legislation which seeks to involve both owners in decisions affecting the entirety of party structures and is certainly the one favoured by the majority of practitioners. Where this first scenario exists therefore, it is suggested that party structure notices should be served irrespective of the side of the structure affected by the work.

Scenario 2: Reliance on Common Law Rights

A second scenario concerns the situation where the proposals are not described within section 2(2) but where, prior to the introduction of the Act, they would nevertheless have been permitted at common law.

This scenario often arises where it is proposed to demolish a building forming part of a terrace in circumstances where no walls are shared with neighbouring buildings. As discussed above, in the context of Photograph 2, unless the appropriate degree of structural connection is present between the brick skins belonging to each building, they are likely to retain their status as separate walls rather than constituting a single a party wall.

Whilst the legislation grants a right to demolish (and rebuild) a party wall (section 2(2)(e)), it grants no such right in respect of a boundary wall situated entirely on a property owner's side of the boundary line. A party structure notice will not therefore be required in this example but, subject to maintaining any existing easements of support, the demolition would nevertheless have been permitted under the previous common law regime.

Contrary to the situation discussed in relation to the first scenario, it is suggested that this type of common law right survives the enactment of the legislation. Where, in the first scenario, the legislation refers to structures which it defines as crossing boundary lines, it is reasonable to assume that its provisions apply to all parts of those structures, irrespective of the position of the boundary line. Where, as in the present context, it makes no reference to a structure at all, it is submitted that no change in the existing law was intended and that any existing rights must be unaffected.

In these situations the property owner is therefore free to undertake the work without giving notice to neighbouring owners despite the fact that a degree of interference or inconvenience may be involved. Where the intrusion is likely to be significant, common sense will usually require that neighbouring owners are notified in any event. This should nevertheless be undertaken outside the provisions of the PWA as any attempts to invoke the legislation in these situations would be without legal validity and any award so produced would be *ultra vires*.

Scenario 3: Trespass to Adjoining Land

The final scenario again concerns the situation where the proposals are not described within section 2(2) but in circumstances where there was no prior common law entitlement to undertake the work either. In these situations any attempt to undertake the work will involve a trespass to adjoining land whether a party structure notice is served or not. Where an evaluation of the proposals has indicated this to be the case, the design should be changed or the consent of the neighbouring owner obtained if the possibility of litigation is to be avoided.

This scenario will often arise where a proposal involves some interference with the external wall of a neighbour's building situated at the boundary line and facing directly onto the property owner's land (Figure 6). The wall may be inaccessible to the neighbouring owner and the property owner may have always regarded the wall as forming part of his own curtilage but the proposal may nevertheless constitute a trespass.

[Take in Figure 6]

The situation is complicated by the fact that certain categories of work are authorised in this situation and it can be difficult to establish whether the proposals fall within

them. For example, the property owner is entitled to cut away projections (section 2(2)(g)) and overhanging features (section 2(2)(h)) from such a wall as well as being permitted to cut into the wall to insert a flashing or other weather-proofing (section 2(2)(j)). He cannot however cut into the wall for any other purpose, nor enclose upon it with a new building of his own.

In many situations it may be expedient to change the design to bring it within the PWA even if the intention is to seek the neighbouring owner's consent to the original proposals at a later date. Once a party structure notice has been served and surveyors appointed by each party, a framework will then exist within which to negotiate an agreement authorising the desired interference with the neighbouring wall. Any agreement so concluded will however fall outside the provisions of the Act and should not therefore be incorporated into the surveyors' award.

Conclusions

The PWA grants important new rights to property owners to undertake construction work to existing boundary structures but makes the exercise of these rights subject to the prior service of a party structure notice on adjoining owners.

These new rights do not only apply to party walls but also to a variety of other structure types referred to in the legislation. Different rights are granted in respect of the different structure types referred to.

Some categories of work are not sanctioned by the legislation, either because the type of work, or the structure affected by it, are not referred to within section 2(2). In some of these situations there will be a common law right to undertake the work in any event, without the requirement for service of a party structure notice. In others,

where no such right exists, undertaking the work will involve the commission of a trespass against an adjoining owner.

The task of determining the requirement for service of a party structure notice is therefore closely related to the question of whether an entitlement to undertake the proposed work exists at all. The precise terminology used in the legislation and the interplay between the statutory and common law rights mean that this question is often not easily answered. The task has also been shown to be further complicated by the vaguaries of situations often encountered on site.

This paper has therefore proposed a systematic approach for evaluating the requirement for service of party structure notices. This involves, so far as possible, approaching each aspect of the decision-making process as a separate task and applying the relevant legal rules to each, before addressing the question as a whole. In adopting such an approach property managers cannot, unfortunately, escape the inherent complexity of the task confronting them. They can however introduce an element of certainty into a complex decision-making task and thereby minimise the risks associated with an incorrect decision.

References

- Anstey, J. (1996) *Party Walls and what to do with them*, RICS Books
- Apostal v Simons (1936) 1 All ER 207
- Bedford, C. (1999) 'When is a wall not a wall?' *Partywalls Discussion Forum* [online] Available from: <http://www.mailbase.ac.uk/lists/partywalls> [Accessed 21 July 1999]
- Bickford-Smith, S. and Sydenham, C. (1997) *Party Walls: the New Law*, Jordans
- Bowden, D. (1999a) 'When is a wall not a wall?' *Partywalls Discussion Forum* [online] Available from: <http://www.mailbase.ac.uk/lists/partywalls> [Accessed 21 July 1999]
- Bowden, D. (1999b) 'Restriction of Common Law Rights' *Partywalls Discussion Forum* [online] Available from: <http://www.mailbase.ac.uk/lists/partywalls> [Accessed 21 July 1999]
- Cubbitt v Porter (1828) 8 B & C 257
- Jones v Pritchard (1908) 1 Ch 630
- Keogh, C. (1999) 'When is a wall not a wall?' *Partywalls Discussion Forum* [online] Available from: <http://www.mailbase.ac.uk/lists/partywalls> [Accessed 21 July 1999]
- LBA (1930) *London Building Act 1930*, Ch. CLVIII
- LBA (1939) *London Building Acts (Amendment) Act 1939*, Ch. XCVII
- LPA (1925) *Law of Property Act 1925*, Chapter 20
- LRR (1925) *Land Registration Rules 1925*, SR & O 1925 No. 1093
- Moss v Smith (1977) 76 LGR 284, CA
- Powell-Smith, V. (1975) *The Law of Boundaries and Fences*, Butterworths
- PWA (1996) *Party Wall etc Act 1996*, Chapter 40
- Rance, I. (1999) 'When is a wall not a wall?' *Partywalls Discussion Forum* [online] Available from: <http://www.mailbase.ac.uk/lists/partywalls> [Accessed 21 July 1999]
- Ruddall, A.R. (1922), *Party Walls*, Jordan & Sons
- Standard Bank of British South America v Stokes (1878) 9 Ch 68
- Truckell v Stock (1957) 1 WLR 161
- Watson v Gray (1880) 14 Ch D 192
- Wignall, G. (1998) *Nuisances*, Sweet & Maxwell

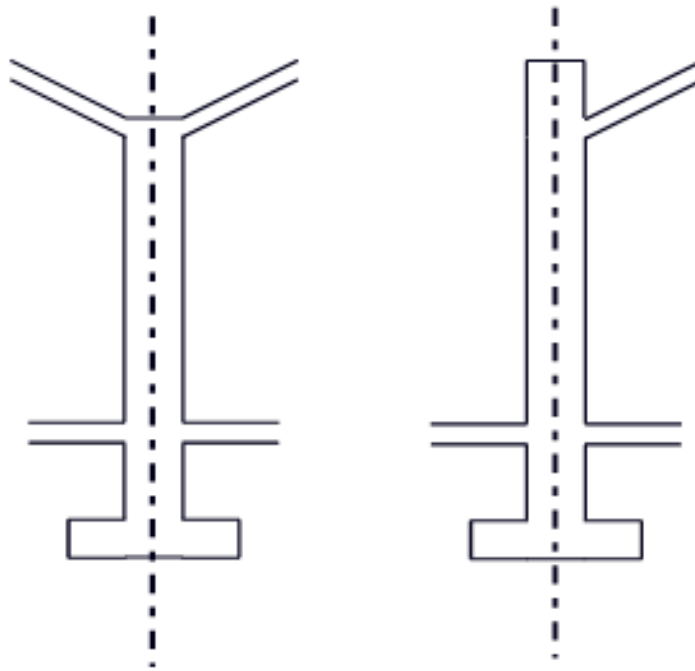

Figure 1: 'Type A' Party Walls

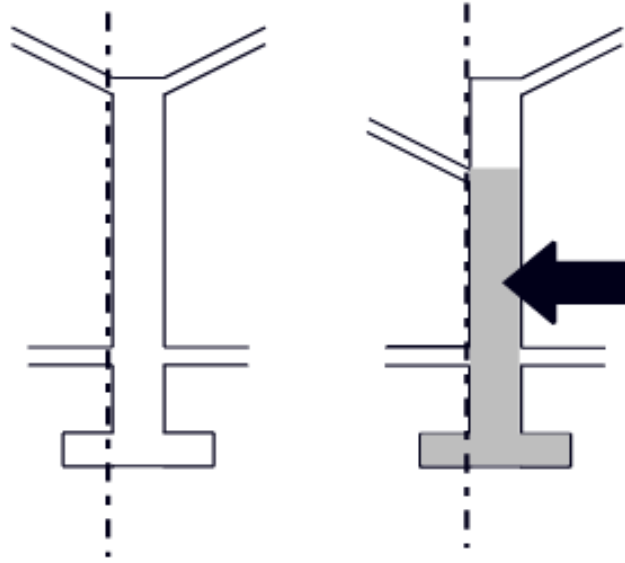

Figure 2: 'Type B' Party Walls

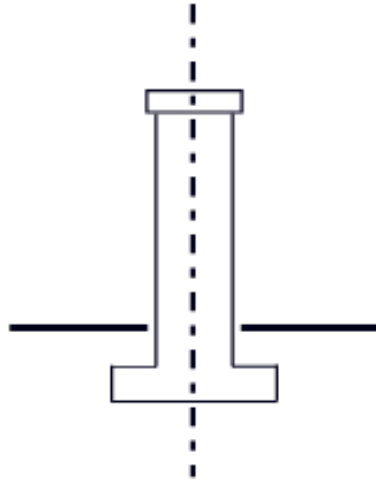

Figure 3: *Party Fence Wall*

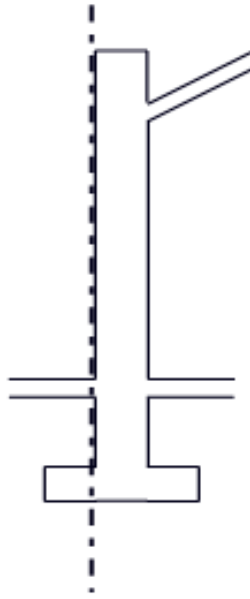

Figure 4: *External Wall*

The term probably only relates to the external walls of buildings rather than to free-standing external walls.

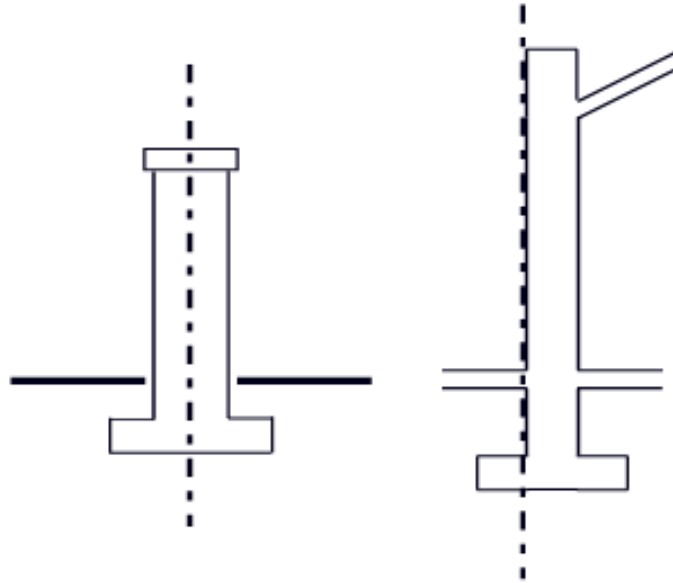

Figure 5: *Boundary Walls*

Although the term is broad enough to refer to any wall which marks a boundary, in the context of service of party structure notices, it refers only to party fence walls and external walls of buildings.

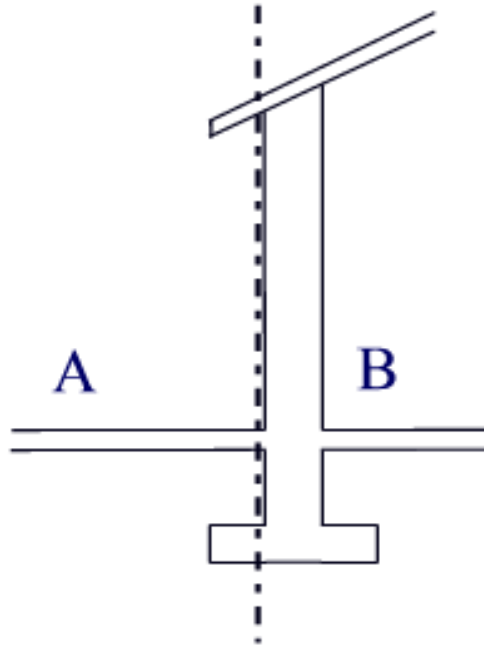

Figure 6: *Trespass to Adjoining Land?*

Owner A now has a statutory right to cut away B's overhanging eaves or projecting foundations and to insert a flashing into B's building. Any attempt by A to cut into this building for any other purpose or to enclose upon it will however constitute a trespass.



Photograph 1

The statutory definitions of the various structure types are often difficult to reconcile with the realities of a situation on site.



Photograph 2

The existence of a party wall will often depend on the degree of connection between two properties built immediately adjoining each other on either side of the boundary line.