



University of
Salford
MANCHESTER

A comparison between the MEXE and Pippard's methods of assessing the load carrying capacity of masonry arch bridges

Wang, J, Haynes, BJ and Melbourne, C

| | |
|--------------------------|---|
| Title | A comparison between the MEXE and Pippard's methods of assessing the load carrying capacity of masonry arch bridges |
| Authors | Wang, J, Haynes, BJ and Melbourne, C |
| Publication title | ARCH '13. Proceedings of the 7th International Conference on Arch Bridges. Trogir-Split, Croatia. October 4-6, 2013. |
| Publisher | SECON - CSSE, Zagred, Croatia. |
| Type | Article |
| USIR URL | This version is available at: http://usir.salford.ac.uk/id/eprint/29550/ |
| Published Date | 2013 |

USIR is a digital collection of the research output of the University of Salford. Where copyright permits, full text material held in the repository is made freely available online and can be read, downloaded and copied for non-commercial private study or research purposes. Please check the manuscript for any further copyright restrictions.

For more information, including our policy and submission procedure, please contact the Repository Team at: library-research@salford.ac.uk.

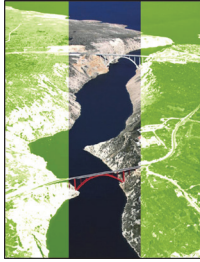

7th International Conference on Arch Bridges

ARCH'13

2 - 4 October 2013

Trogir - Split, Croatia

MAINTENANCE, ASSESSMENT AND REPAIR

A COMPARISON BETWEEN THE MEXE AND PIPPARD'S METHODS OF ASSESSING THE LOAD CARRYING CAPACITY OF MASONRY ARCH BRIDGES

Jinyan Wang^{*}, Jonathan Haynes⁺ & Clive Melbourne[#]

^{*} University of Salford, Directorate of Civil Engineering, Salford, UK.
j.wang@salford.ac.uk

⁺ University of Salford, Directorate of Civil Engineering, Salford, UK
b.j.haynes@salford.ac.uk

[#] University of Salford, Directorate of Civil Engineering, Salford, UK
c.melbourne@salford.ac.uk

Keywords: Masonry arch, assessment, MEXE, long span.

Abstract: *The Military Engineering eXperimental Establishment (MEXE) method is a long established system of masonry arch load carrying capacity assessment. It has been subject to review in recent years and some shortcomings have been identified. There is now growing consensus that the current version of MEXE overestimates the load carrying capacity of short span bridges, but for spans over 12m it becomes increasingly conservative. In this paper Pippard's elastic method and the MEXE method are used to investigate the significance of factors such as fill cover, ring thickness and effective width of arch barrel, and their effect upon the load-carrying capacity predictions in short and long span arches. Conclusions are drawn which establish directions of new research and offer guidance to assessors of short and long span masonry arch bridges.*

1 INTRODUCTION

The assessment of masonry arch bridge load carrying capacity has traditionally been undertaken using the Military Engineering Experimental Establishment (MEXE) method (or a modified version of this). The MEXE method comprises the calculation of a provisional axle load (*PAL*) that relates to the performance of a 'standard' arch barrel using either a nomogram given in the Advice Notice BA16/97 [1] or the equation:

$$PAL = 740 \frac{(d+h)^2}{L^{1.3}} \leq 70 \quad (1)$$

where *PAL* is measured in Tonnes, *L* is the span (in metres), *d* is the thickness of the arch barrel adjacent to the keystone (in metres), and *h* is the depth of fill (in metres) at the crown, including any road surfacing.

The MEXE method may lead, in some circumstances, to over-conservative or under-conservative predictions. As stated in the current bridge assessment code BA16/97, the MEXE method may be used to estimate the carrying capacity of arches spanning up to 18.0m, but for spans over 12.0m it becomes increasingly conservative compared to other methods.

In recent years, the method has been the subject of some criticism in particular with respect to determining the load carrying capacity of short span bridges [3][4]. There is now growing consensus that the current version of MEXE overestimates the load carrying capacity of short span bridges. A recent investigation of the assessment methods for masonry arch bridges has presented one of the possible reasons why Pippard's method might overestimate the load carrying capacity of short span bridges and also identified other shortcomings of the elastic method [5].

Although it is generally accepted [3][6] that the MEXE method evolved from the work undertaken by Pippard in the 1930's [7][8], the exact method by which the nomogram or the MEXE equation in Advice Notice BA16/97 were developed remains unknown. It seems likely that the empirical decisions that were made at the time of the development of the original MEXE method (perhaps regarding practical relationships between geometrical parameters and material properties) will be impossible to reconstruct based upon reliable published data.

The purpose of this paper is to investigate the correlation of the allowable loads predicted by the MEXE method and Pippard's elastic method and attempts to find the causes of the overestimation or underestimation of load carrying capacity suggested by MEXE. It also attempts to examine the significance of other factors inherent in the MEXE method.

2 COMPARISON OF ALLOWABLE LOADS FROM THE MEXE METHOD AND PIPPARD'S ELASTIC METHOD

In accordance with Pippard [8] for a point load *W* at the crown of a parabolic arch, the compressive stress under the combined dead and live load should not exceed the maximum permitted value of the compressive stress *f_c* giving the limiting value of the point load *W* at the crown as:

$$W = \frac{\frac{256f_c h d}{L} - 128\rho L h \left(\frac{1}{21} + \frac{h+d}{4a} - \frac{a}{28d} \right)}{\left(\frac{25}{a} + \frac{42}{d} \right)} \quad (2)$$

where d , h and L are defined under Equation 1, a is the arch central rise (in metres), f_c is the limiting compressive stress and ρ is the density of the fill and masonry (assumed to be the same). The full derivation of the equation can be found elsewhere [5].

Considering that a typical vehicle axle will comprise two wheel loads side by side, the safe axle load W_A obtained by Pippard was,

$$W_A = 2W \quad (3)$$

The tables constructed by Pippard [8] for predicting the safe loads on masonry arch bridges were based on that the density of the fill and masonry $\rho = 2.24 \text{ Mg/m}^3$, the span:rise ratio (L/a) was 4:1, the limiting compressive stress at the crown $f_c = 1400 \text{ kN/m}^2$, and a limiting tensile stress $f_t = 700 \text{ kN/m}^2$.

The spans of the bridges covered by Pippard are from about 3.0 m to 15.0 m (10 ft to 50 ft). A comparison of the allowable axle loads calculated using the MEXE method (Equation 1) and from Pippard's table [8] for single point loadings is shown in Figure 1 to Figure 3. The span, fill depth and arch ring thickness used to generate Figures 1 to 3 are taken from Pippard's table and are listed here, in Table 1.

| h m (inches) | $L = 3.048 \text{ m (10 ft)}$ | $L = 12.192 \text{ m (40 ft)}$ | $L = 15.24 \text{ m (50 ft)}$ |
|-------------------|-------------------------------|--------------------------------|-------------------------------|
| | d m (inches) | | |
| 0 (0) | 0.229 (9) | | |
| 0.152 (6) | 0.343 (13½) | | |
| 0.305 (12) | 0.457 (18) | 0.457 (18) | |
| 0.457 (18) | | 0.572 (22½) | 0.572 (22½) |
| 0.610 (24) | | 0.686 (27) | 0.686 (27) |

Table 1: Parameter values used for capacity assessments

It can be seen in Figure 1, that for smaller spans the allowable axle loads predicted by the MEXE equation are significantly higher than Pippard's tabular data. This suggests that the MEXE method overestimates the allowable loads of short span bridges when compared with Pippard's elastic method for a single point load at the crown even considering that the maximum axle load from MEXE is 70 tons.

Since the capacity is related to $(d+h)^2$ the allowable axle loads diverge with increasing fill and arch ring thickness. The divergence in capacities lies between 56% and 78% if the limit on compressive stress is applied.

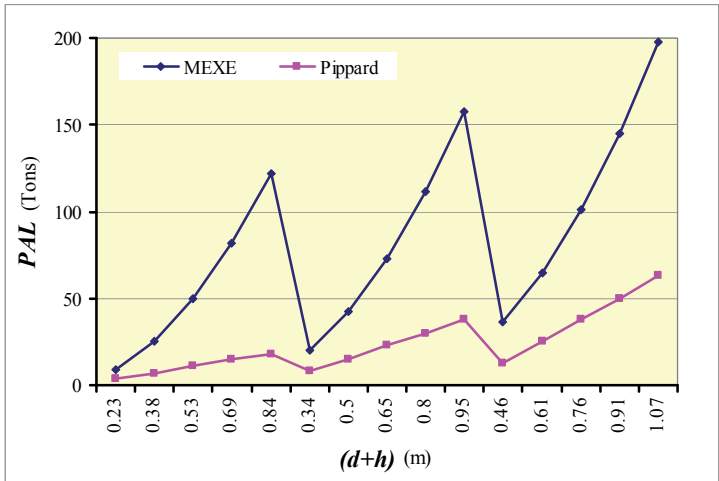

Figure 1: Allowable axle loads for $L=3.048$ m (10 ft)

When the allowable axle load predicted by Pippard’s elastic method is reached for spans between 10 ft and 20 ft, the arch barrel masonry can be subject to tensile stresses in excess of 0.7 N/mm^2 . If the tensile stress criterion is strictly applied then the allowable loads will be lower than the Pippard tabular values shown in Figure 1. However, when the bridge span reaches about 12.0m (40 ft), the two methods produce almost identical results, as shown in Figure 2.

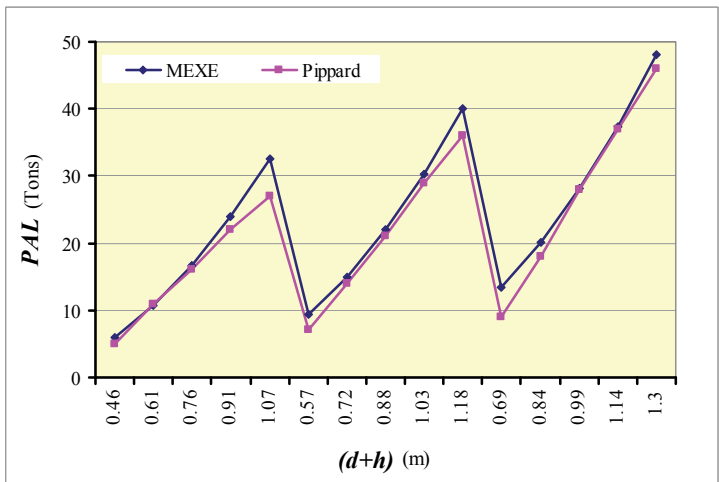

Figure 2: Allowable axle loads for $L=12.192$ m (40 ft)

For spans over 12.0m, the MEXE equation predicts consistently lower allowable loads when compared with Pippard's values. The difference becomes more significant with increasing bridge span.

Once outside the range considered by Pippard [8], the allowable loads predicted are much higher than those predicted by MEXE, as shown in Figure 3 for spans of 18.0m (60ft). This suggests that the MEXE method becomes increasingly conservative when compared to Pippard's elastic method, for relatively large span bridges. The divergence in capacities lies between 18% and 47%.

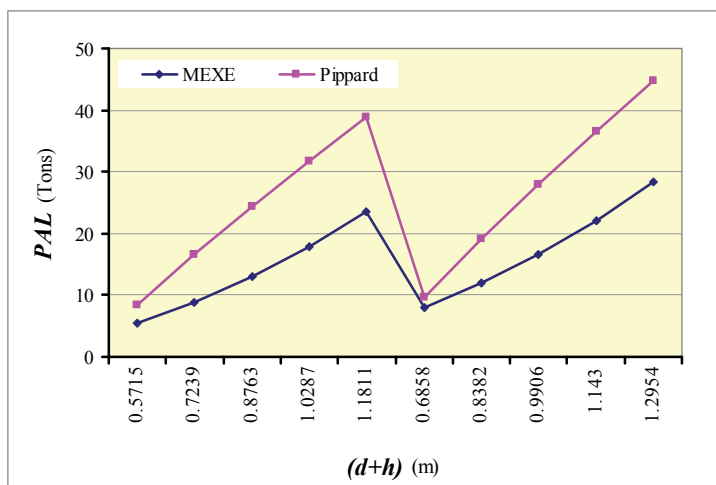

Figure 3: Allowable axle loads for $L=18.288$ m (60 ft)

It should be noted that for some 15.0m (for $d=22.5$ inches), and all 18.0m spans, the compressive criterion is reached at the crown section under self-weight only. Pippard's formula was based upon limiting the compressive stress at the crown extrados under combined dead and live load. If however, Pippard's original stress criteria are strictly applied then the bridge will 'fail' the compression criterion under self-weight only. In which case, the safe axle load will drop to zero.

3 OTHER RELEVANT ISSUES

3.1 Effective width

A conventional 45 degree load dispersion angle was taken by Pippard [5] from the road surface through the fill to the arch barrel. In this way the width of the arch barrel affected by a point load was at least twice the depth of fill at the loaded point. Since the fill is of least thickness at the crown, the effective width adopted by Pippard was conservatively taken to be $2h$, as shown in Figure 4.

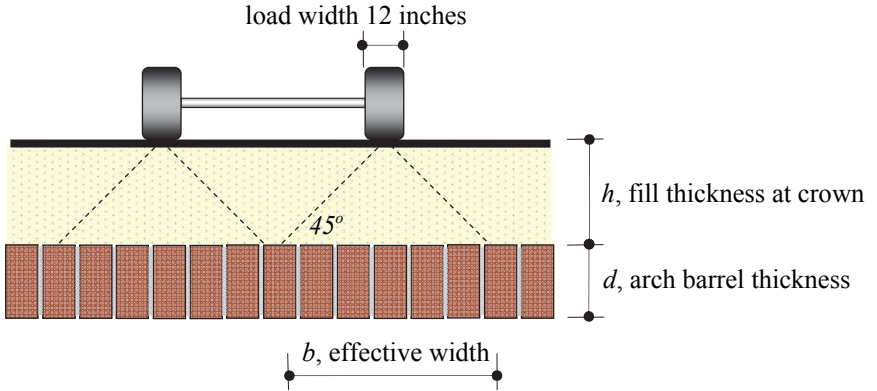

Figure 4: Effective width adopted by Pippard

To study the influence of the effective width of the arch rib b , let b increase from b_1 to b_2 , the remainder of the parameters being unchanged. Since the available live load stress P_a [5] does not change:

$$W_1 = \frac{P_a}{\left(\frac{H_L}{b_1 d} + \frac{6M_L}{b_1 d^2}\right)} = \frac{P_a}{\frac{1}{b_1} \left(\frac{H_L}{d} + \frac{6M_L}{d^2}\right)}$$

$$W_2 = \frac{P_a}{\left(\frac{H_L}{b_2 d} + \frac{6M_L}{b_2 d^2}\right)} = \frac{P_a}{\frac{1}{b_2} \left(\frac{H_L}{d} + \frac{6M_L}{d^2}\right)} \quad (4)$$

$$\therefore \frac{W_1}{W_2} = \frac{\frac{P_a}{\frac{1}{b_1} \left(\frac{H_L}{d} + \frac{6M_L}{d^2}\right)}}{\frac{P_a}{\frac{1}{b_2} \left(\frac{H_L}{d} + \frac{6M_L}{d^2}\right)}} = \frac{b_2}{b_1} \quad \therefore W_2 = \frac{b_2}{b_1} W_1 \quad (5)$$

where

$$P_a = f - \left(\frac{H_D}{d} + \frac{6M_D}{d^2}\right) \quad (6)$$

H_D and M_D are horizontal thrust and bending moment at the crown due to the dead load of a unit width bridge, H_L and M_L are horizontal thrust and bending moment at the crown due to a unit live load at the crown.

The effective bridge width adopted by Pippard [8] is equivalent to $4h$. This infers that axle load will increase in direct proportion to the fill depth. When this is combined with significant variations in the interpretation of effective width, which exist across masonry arch bridge owners, there is potential for hazardous overestimation of capacity.

3.2 Effective depth

The assumption that the width of the effective arch rib was twice the depth of the fill, led to difficulties for a point load when $h=0$ metres. Pippard argued that the tyres or track did not impose a point load but spread the load over a width of about 12 inches, as shown in Figure 5. An allowance of 6 inches was therefore added to the actual depth of fill (h) giving the effective depth of fill as $h+6$ inches. The effective depth of fill was used throughout the calculation of tabular values by Pippard [8].

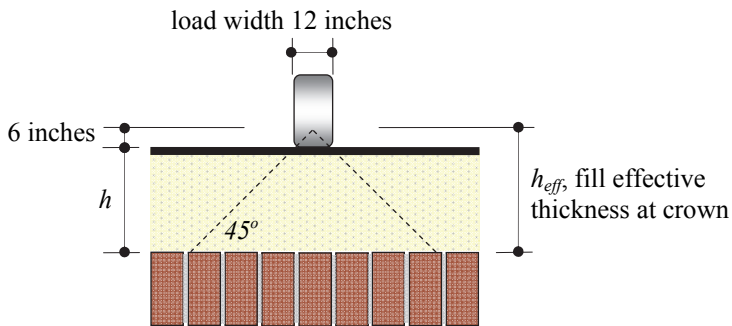

Figure 5: Effective depth of fill

4 CONCLUSIONS

It is generally accepted that the MEXE method of assessment is derived from Pippard's elastic method (with a point load at the crown). However, predicted capacities from both methods only agree for a mid-range span of about 12m. It is likely that the MEXE method is derived from a regression analysis using common masonry arch bridge spans.

For larger spans (over 15m), the MEXE method predicts lower permissible axle loads than Pippard's elastic method. The difference between predicted values being up to 47%. This conservatism is safe.

For smaller spans (3m to 5m), the MEXE method predicts much higher permissible axle loads than Pippard's elastic method. The difference between predicted values being up to 78%. This is potentially unsafe.

In an assessment of all possible combinations of span, fill depth and arch ring thickness investigated by Pippard; capacities of 13 (out of 60) arrangements were controlled by the tensile stress limitation but the maximum reduction in capacity was only 13%. These were all in the 10, 15 or 20 ft span bridges. Capacities of half the 50 ft span arrangements were controlled by the compressive stress limitation. Capacities of all 60 ft (or greater) span arrangements were controlled by the compressive stress limitation.

There is potential danger in the continued variation in interpretation of effective loaded width. The topic of effective load width requires further research and standardisation, particularly to establish the true distribution of stress under wheels and sleepers.

REFERENCES

- [1] Highway Agency. 2001. *Highway structures: Inspection and maintenance. Assessment. Assessment of highway bridges and structures*. DMRB Volume 3 Section 4 Part 4 (BA 16/97). London: HMSO.
- [2] Highway Agency. 2001. *Highway structures: Inspection and maintenance. Assessment. The Assessment of highway bridges and structures*. DMRB Volume 3 Section 4 Part 3 (BD 21/01). London: HMSO.
- [3] McKibbins, L., Melbourne, C., Sawar, N. and Gaillard, C.S. 2006. *Masonry arch bridges: condition appraisal and remedial treatment*. CIRIA C656.
- [4] Harvey, W.J. 2007. *Review of the Military Engineering Experimental Establishment (MEXE) method*. Report to the International Union of Railways. Paris, UIC Project I/03/U/285.
- [5] Wang, J., Melbourne, C. 2010. Mechanics behind the MEXE method for masonry arch assessment, *Journal of Engineering and Computational Mechanics, Proceedings of the Institution of Civil Engineers*, Vol. 163, EM3, 187-202
- [6] Heyman, J. 1982. *The masonry arch*. Chichester: Ellis Horwood Limited.
- [7] Pippard, A.J.S., Tranter, E. and Chitty, L. 1936. The Mechanics of the Voussoir Arch, *J. ICE*, Vol. 4, 281-306.
- [8] Pippard, A.J.S. 1948. The approximate estimation of safe loads on masonry bridges, *Civil Engineer in War*, Vol. 1, 365-372.

ACKNOWLEDGEMENT

The authors wish to acknowledge the support given by UIC, CSS and the University of Salford.